



Data Sheet Wöhr Turntable 505

Suitable for condominium and office buildings.

Turntable 505-2,5: Load bearing capacity max. 2500 kg (wheel load max. 625 kg)

Dimensions in cm

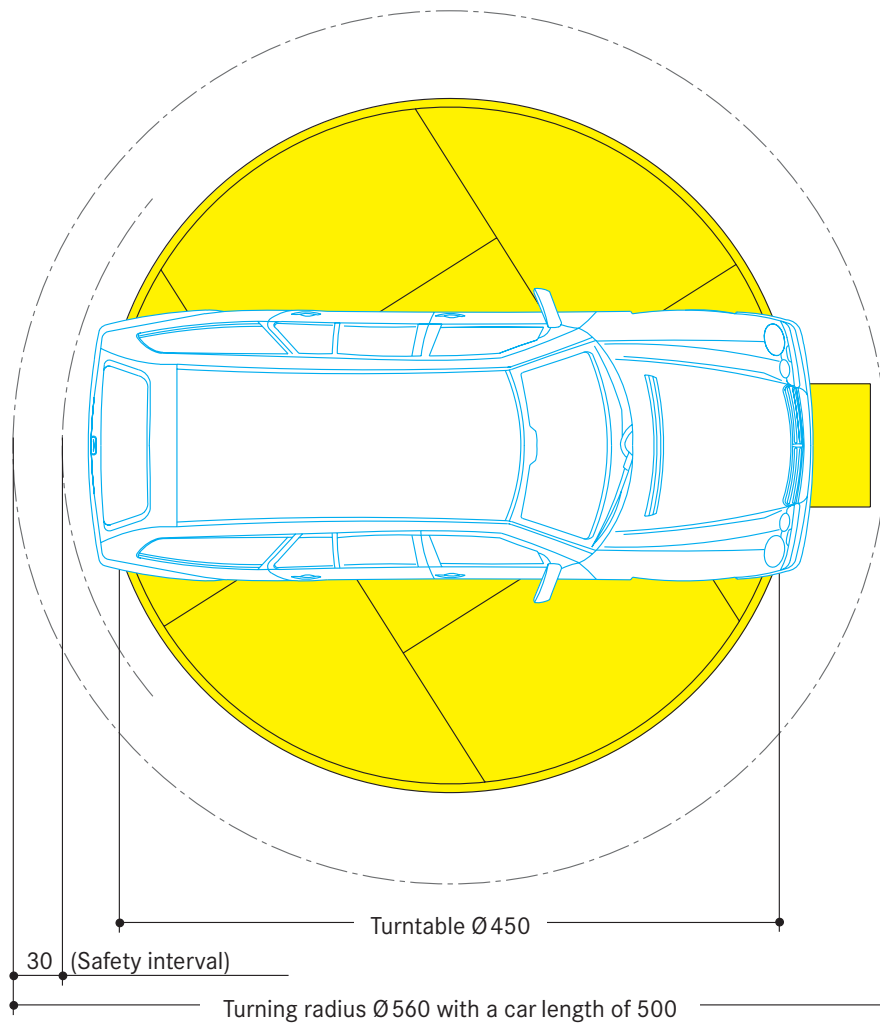
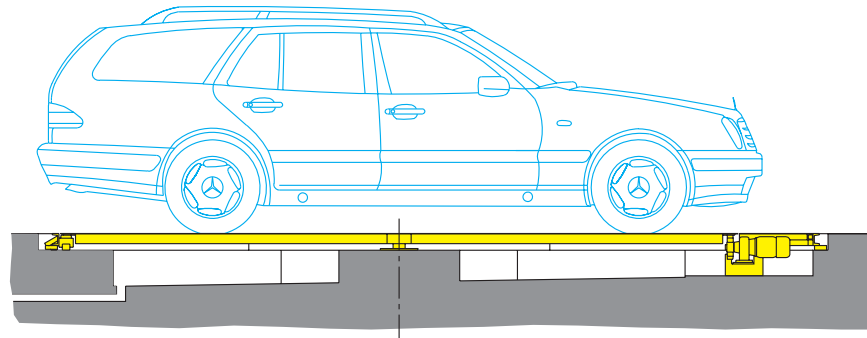

Notes

1. The pit and possible drainage facilities are to be supplied by the customer.
2. Operation is effected via a control knob – turn left/turn right (hold-to-run-device).
3. Observe the car exterior contours vis-à-vis the structural dimensions (e.g. car length 500 cm = 560 cm turning radius)
4. The standard version is not suited for setting up outdoors.
5. The manufacturer reserves the right to modify or alter above specifications.

Foundation dimensions and structure

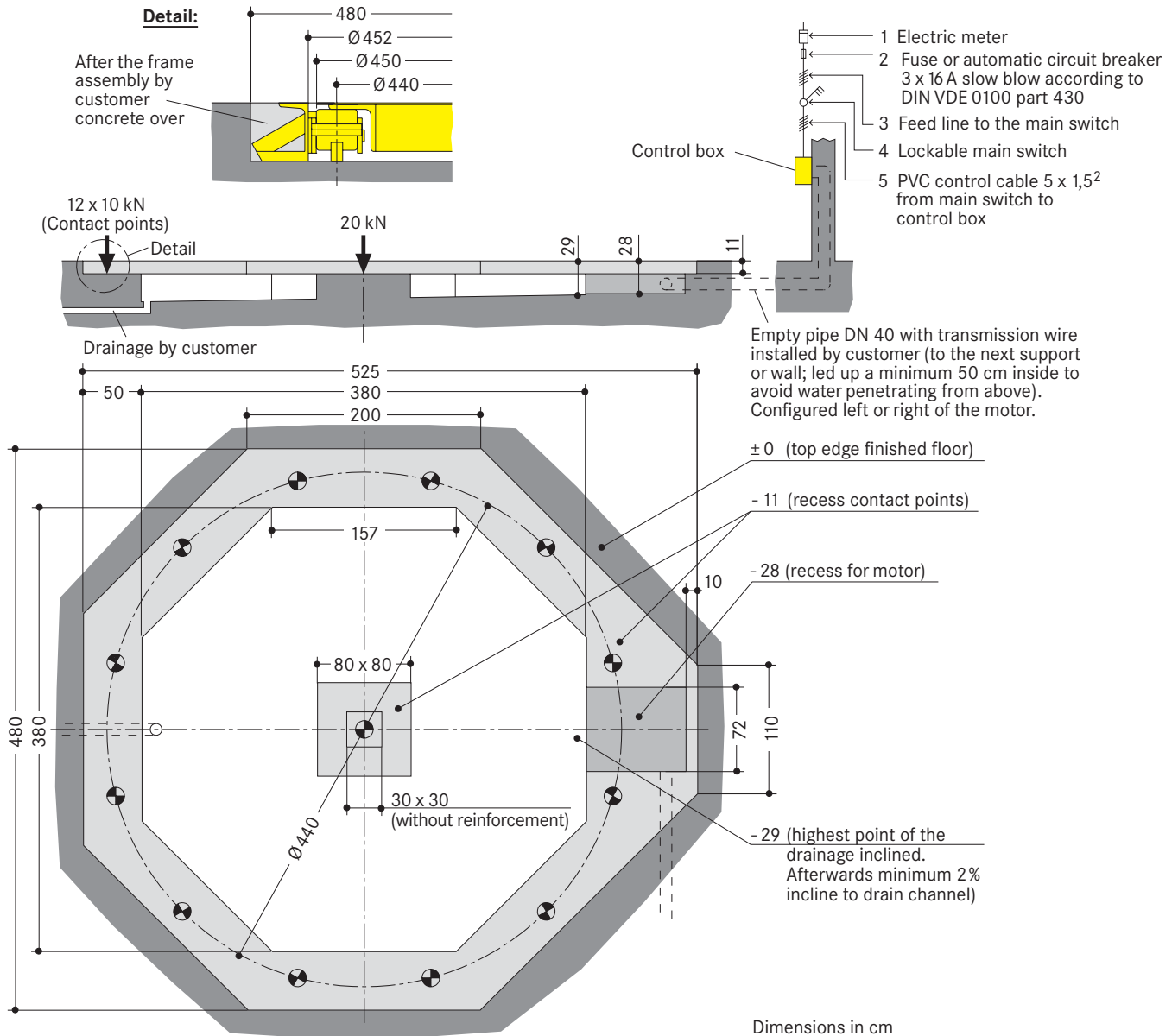

Power consumption

0,37 kW (1,07 rpm)

Electrical datas

Item	Performance	Quantity	Designation	Position	Frequency
1	by customer	1 unit	electric meter	in the feed cable	
2	by customer	1 unit	fuse or automatic circuit breaker 3 x 16 A slow blow acc. to DIN VDE 0100 p. 430	in the feed cable	1 per turntable
3	by customer	as locally required	acc. to local power supply regulations 3 Ph + N + PE*	feed cable to main switch	1 per turntable
4	by customer	1 unit	marked main switch, lockable to prevent unauthorized switching on	in the feed cable above control box	1 per turntable
5	by customer	2 m	PVC control cable with marked strands and protective conductor 5 x 1,5 ²	from main switch to control box	1 per turntable

* DIN VDE 0100 part 410 + 430 (not under permanent load) 3PH+N+PE (three-phase current)

The electrical components supplied by the manufacturer must be connected in accordance with the appropriate wiring diagram and local regulations. German VDE electrical requirements must be adhered to, in order to validate the TÜV tested circuit.

The electrical supply to the power pack(s) must be provided prior to or during installation to enable our fitters to complete their work satisfactorily and to check the correct functioning of the units.

Temperature

The installation is designed to operate between +5° and +40°C. Atmospheric Humidity: 50% at +40°C. If the local circumstances differ from the above please contact Wöhr.

Maintenance

Regular maintenance by qualified personnel can be provided by means of an Annual Service Contract.

Protection against corrosion

Independent of a maintenance workings has to be carried out acc. to Wöhr Cleaning and Maintenance Instruction regularly.

Clean up turntable of dirt and road salt as well as other pollution (corrosion danger)!

Drainage

The pit and the drainage of the pit have to be provided by client. To prevent hazards for the ground water, we recommend giving the pit floor an oil-resistant coating

as a means of protecting the environment. If this is to be connected to the sewage system, it is advisable to provide oil and/or petrol separators.

Dimensions

All dimensions shown are minimum. Construction tolerances must be taken into consideration. All dimensions in cm.

Conformity test

All our systems are checked according to EC machinery directive 2006/42/EC and EN 14010.