

* In case of short time user (e.g. for office-, hotel-, commercial building) only possible on lower platform and only if technically adjusted, ask WÖHR! Or with attendant or valet parking both levels are possible for short time user.

Load per platform
max. 2000 kg
(load per wheel 500 kg)

Dimensions in cm

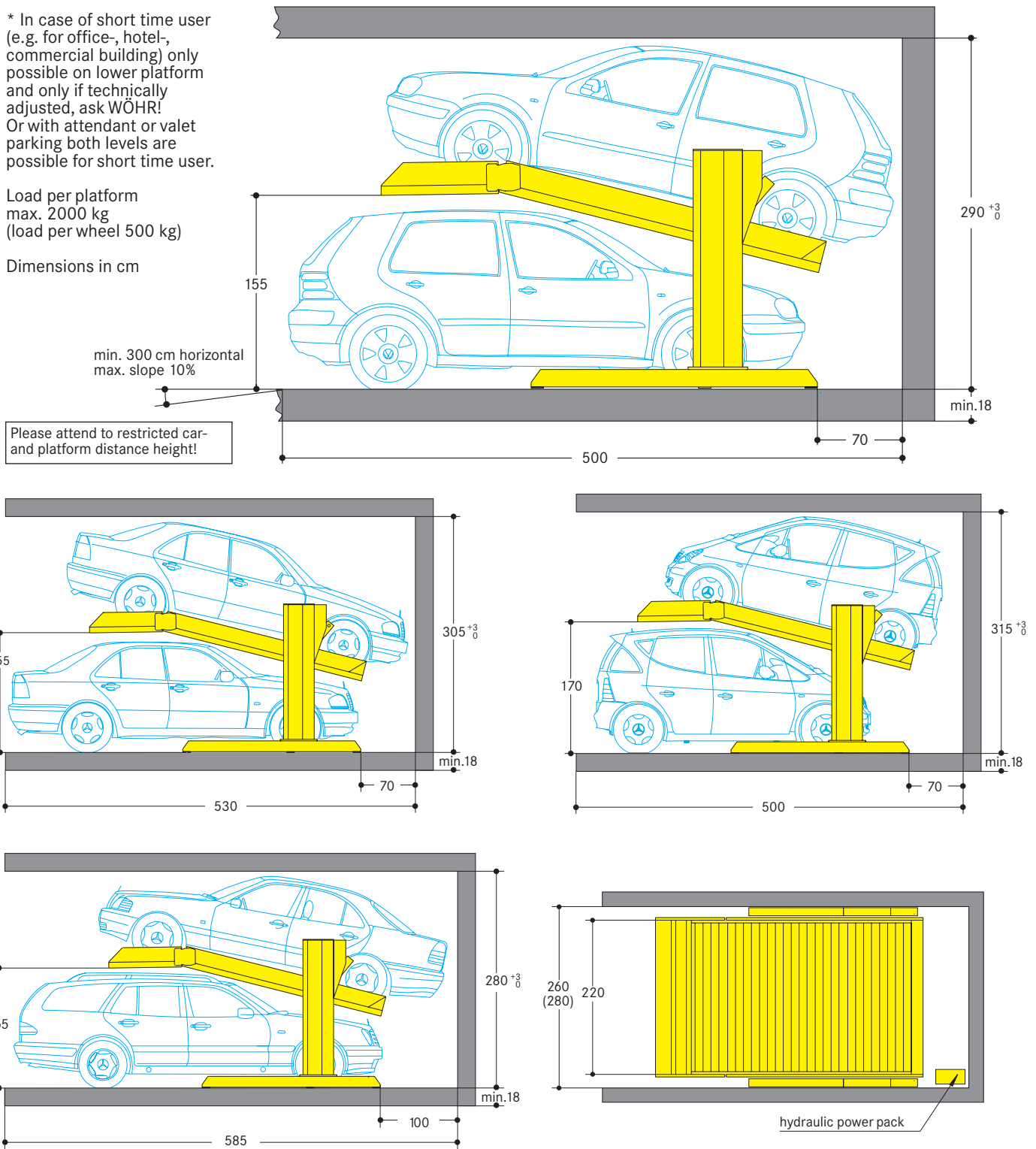

Notes

1. According to the examples shown above the required height and length dimensions depend on the car size and parking direction (frontwards/reverse).
2. Max. car width 190 cm, clear platform width 220 cm. Installation width 260 cm (forwards), installation width 280 cm (forwards and reverse parking).
3. According to ISO 3864 the floor has to be marked with 10 cm wide yellow-black stripes at a distance of 90 cm from the platform edge by the purchaser (see "statics and construction requirements" on page 2).
4. It is not possible to have channels or undercuts and/or concrete haunches along the floor-to-wall joints. In the event that channels or undercuts are necessary, the system width needs to be reduced or the installation width needs to be wider.
5. The manufacturer reserves the right to modify or alter above specifications.

Electrical datas

Item	Performance	Quantity	Designation	Position	Frequency
1	by customer	1 unit	electric meter	in the feed cable	
2	by customer	1 unit	fuse or automatic circuit breaker 3 x 16 A slow blow acc. to DIN VDE 0100 p. 430	in the feed cable	1 per power pack
3	by customer	as locally required	acc. to local power supply regulations 3 Ph + N + PE*	feed cable to main switch	1 per power pack
4	by customer	each 10 m	equipotential bonding safety lead-out connection	corner pit floor/ rear wall	
5	by customer	1 unit	equipotential bonding safety compliant to the DIN EN 60204 standard	from the lead-out connection to the system	1 per Parklift
6	by customer	1 unit	marked main switch, lockable to prevent unauthorized switching on	above operating device	1 per power pack
7	by customer	10 m	PVC control cable with marked strands and protective conductor 5 x 1,5 ²	from main switch to hydraulic power pack	1 per power pack

Items 8–16 are included in Wöhr's scope of delivery unless otherwise specified in the offer/order.

* DIN VDE 0100 part 410 + 430 (not under permanent load) 3PH+N+PE (three-phase current) Note: Where a door is used to close the garage, the manufacturer of the door must be consulted before the electric cable is laid.

The electrical components supplied by the manufacturer must be connected in accordance with the appropriate wiring diagram and local regulations. German VDE electrical requirements must be adhered to, in order to validate the TÜV tested circuit.

The electrical supply to the power pack(s) must be provided prior to or during installation to

enable our fitters to complete their work satisfactorily and to check the correct functioning of the units.

In compliance with the DIN EN 60204 standard provisions, all systems must be connected directly on site with an earthed equipotential bonding. The lead-out connection must be at a 10 m distance!

Installation diagram

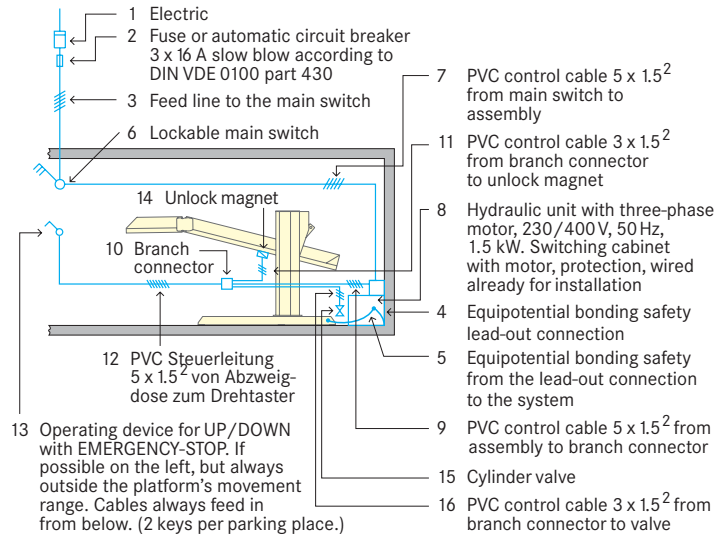

Maintenance

Regular maintenance by qualified personnel can be provided by means of an Annual Service Contract.

Protection against corrosion

Independent of a maintenance workings has to be carried out acc. to Wöhr Cleaning and Maintenance Instruction regularly.

Clean up galvanized parts and platforms of dirt and road salt as well as other pollution (corrosion danger)!

Pit must be always ventilated and deaired well.

Noise protection

Basis is the German DIN 4109 "Noise protection in buildings".

With the following conditions required 30 dB (A) in rooms can be provided:

- noise protection package from our accessory
- insulation figure of the construction of min. $R'_w = 57$ dB
- walls which are bordering the parking systems must be done as single wall and deflection resistant with min. $m^2 = 300$ kg/m²
- solid ceiling above the parking systems with min. $m^2 = 400$ kg/m²

At differing constructional conditions additional sound absorbing measures are necessary.

The best results are reached by separated sole plates from the construction.

Increased noise protection:

If increased noise protection must be provided planning has to be confirmed on a project basis by Wöhr (further building measures are required).

Statics and construction requirements

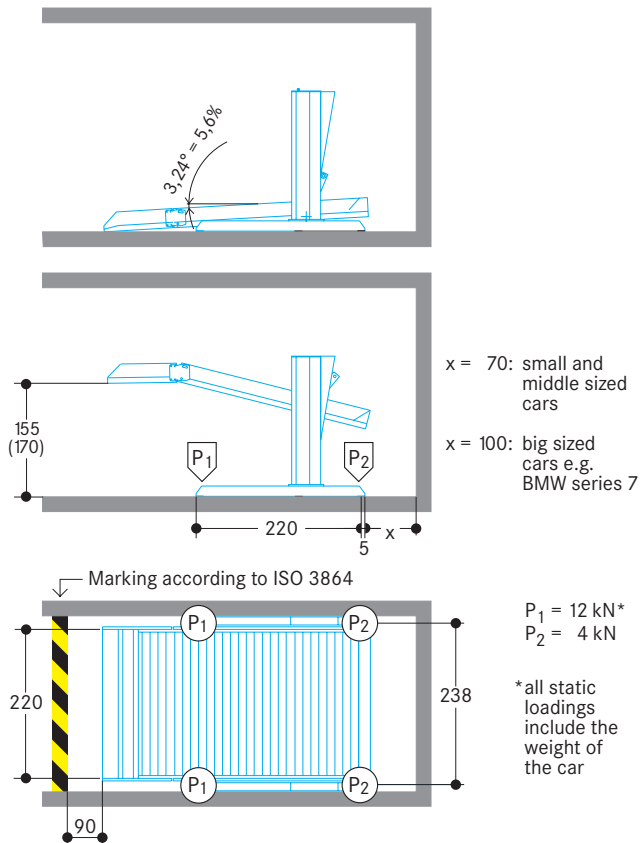

The Parkbox will be fixed on the anchor points with heavy duty anchor bolts to a depth of approx. 10–12cm.

Slab thickness min. 18cm. Concrete quality according to the static requirements of the building, but for the dowel fastening we require a concrete quality of min. C20/25.

Special foundations are required with asphalt floors or paving-stones.

Temperature

The installation is designed to operate between +5° and +40°C. Atmospheric Humidity: 50% at +40°C. If the local circumstances differ from the above please contact Wöhr.

Conformity test

All our systems are checked according to EC machinery directive 2006/42/EC and EN 14010.

Dimensions

All dimensions shown are minimum. Construction tolerances must be taken into consideration. All dimensions in cm.

Railings

If walkways are arranged directly to the side or behind the systems, railings have to be provided acc. EN ISO 13857 by client acc. to local requirements, height min. 200cm.

Notes

In case of lower cars with spoilers, contact Company Wöhr or local agent.